

TURBINA TIPA SAXO – KOMBINACIJA CEVNE IN KAPLANOVE TURBINE SAXO TYPE TURBINE – COMBINATION OF TUBULAR AND KAPLAN TURBINE

Edvard HÖFLER

S turbino tipa Saxo se je Litostroj v zadnjih letih uveljavil v Kanadi. To je vertikalna aksialna turbina, ki je od vstopa do gonilnika podobna cevni turbini z vstopnim kolenom in polaksialnim vodilnikom, od vključno gonilnika do konca sesalne cevi pa podobna običajni kaplanovi turbini. Ta tip turbine lahko pokriva področje uporabe cevni in kaplanovih turbin. V prispevku so razložene konstrukcijske in hidrodinamične značilnosti turbine Saxo, zaradi katerih je posebej zanimiva in obetavna. Predstavljeni so rezultati teoretično-računskih raziskav toka skozi vodilnik in gonilnik turbine. Prednost koničnega vodilnika je v tem, da generira zmerno vsiljen vrtilinec, zaradi katerega je porazdelitev hitrosti pred lopatami gonilnika bolj enakomerna. Računske analize so pokazale, kje so tista kritična mesta, ki zadevajo tokovne razmere, izvore prekomernih izgub in kavitacije. Vse te obetavne napovedi bi bilo treba potrditi s preskusom na modelu turbine.

Ključne besede: vertikalna cevna vodna turbina, konstrukcija, vodilnik, gonilnik, tokovne razmere

During the last decade in Canada, a turbine of the Saxo type has become a well-recognised product of Litostroj. Saxo is a vertical axial turbine whose construction between the turbine inflow and the runner is similar to tubular turbines with an inlet elbow and semi-axial i.e., conical guide apparatus. Between the runner inlet and the turbine outflow it is similar to conventional Kaplan turbines. This turbine is suitable for covering both operating ranges of Kaplan and tubular turbines. In this paper we describe the advantages of the design and the hydrodynamic characteristics of the Saxo-turbine. The results of the theoretical and numerical investigations of the flow field in the distributor and runner regions are presented. The advantage of the semi-axial distributor is its capability for generating a slightly forced vortex flow, due to which the velocity distribution ahead of the runner blading becomes more uniform. Numerical analysis helped us in identifying the regions of unsatisfactory flow conditions that might be potential sources of power losses and cavitation.

Keywords: vertical tubular hydro turbine, construction, guide apparatus, runner, flow conditions

1. UVOD

S tem prispevkom želim strokovno javnost približe seznaniti z vrsto turbine, s katero se je Litostroj uveljavil v Kanadi. Prvo elektrarno s tako turbino (St. Anne) smo pognali spomladi l. 1997, druga (Jean-Guerin) se vrtil od spomladi l. 1998, tretja (Riverin) pa je stekla jeseni l. 1999.

Naziv tipa turbine Saxo ni mednarodno razširjen, verjetno pa izvira iz Kanade in velja za aksialno turbino v S konfiguraciji. Slika 1 shematično kaže tipično elektrarno z dovodnim cevovodom, vgrajeno turbino Saxo

1. INTRODUCTION

The purpose of the present contribution is to introduce our professional community to the type of turbine that has been most widely installed in Canada by Litostroj. After the first power plant with this type of turbine which started operating in Spring, 1997 (St. Anne) we built the second one in Spring, 1998 (Jean-Guerin), and also installed the third one in Autumn, 1999 (Riverin).

The name Saxo turbine is not yet well recognised on an international level. This name originates most probably from Canada, and has been usually accepted for axial turbines in 'S'-design configurations. In Figure

z vertikalno osjo in samostojno stoječim generatorjem. Dovod vode je po cevovodu horizontalno ali pa tudi poševno od zgoraj. Pravzaprav je to kaplanova turbina brez spirale, ima pa konični vodilni aparat. Namesto spirale kratko koleno s smernimi lopatami ter z ustreznim kotom usmeri tok navzdol proti predvodilniku in vodilniku. Skozi to koleno je izveden prehod turbinske gredi za odvzem momenta. Pod gonilnikom je kratek konični difuzor, ki prehaja v horizontalno koleno in pravokotno razširjeno sesalno cev. Ta tip turbine lahko pokriva področje uporabe cevskih in kaplanovih turbin: neto višine od nekaj metrov do 30 metrov ali več, zahvaljujoč kompaktni konstrukciji turbine. Tudi gradbena dela so zelo poenostavljena.

V naslednjih poglavjih bom osvetlil konstrukcijske in hidrodinamične značilnosti turbine Saxo, zaradi katerih je posebej zanimiva in obetavna.

2. KONSTRUKCIJA TURBINE

Predmet našega zanimanja je turbina z naslednjimi podatki: premer gonilnika 1900 mm, 5 lopat gonilnika, 12 lopat vodilnika, vrtilna hitrost 300 min^{-1} , ki bo pri neto padcu $H_n = 21,2 \text{ m}$, delovala v območju pretoka $Q = 9 \text{ do } 27 \text{ m}^3/\text{s}$. Slika 2 prikazuje prerez skozi konstrukcijo take turbine.

Vtočni referenčni presek, ki ga uporabljamo za presojanje zmogljivosti turbine, leži pred vstopnim kolenom s smernimi lopatami, ki ga jemljemo za del turbine. Taka kolena so pri standardnih konfiguracijah znanih tipov turbin precej neobičajna. Kompaktna kolena s smernimi lopatami so dobro eksperimentalno raziskana (Idelchik, 1986). Tu nas zanima predvsem koeficient izgub. Če upoštevamo navodila za oblikovanje okrova kolena in lopat ter zmanjšanje preseka zaradi zaščitne cevi za prehod gredi, koeficient izgub ζ ni višji od 0,2 do 0,21. Po podatkih iz navedene literature ugotavljamo, da je mogoče 90° kompaktno koleno še nekoliko izboljšati - do koeficienta izgub pribl. 0,195. Ta cilj bi lahko dosegli z večjim številom profiliranih lopatic.

A typical power plant with penstock, a Saxo turbine with a vertical axis and an independently placed generator, is shown. The water is fed through the horizontal or inclined penstock. This turbine essentially belongs to the Kaplan type; however, without a spiral case, but with a conical distributor. Instead of a spiral case, there is a compact elbow with guide vanes, which predetermines the flow downstream to the guide vanes and the runner. The vertical shaft alignment for the torque transmission is fed through this elbow. Below the runner there is a relatively short conical diffuser with an elbow and the square-sectioned draft tube. Due to their compact construction, turbines of this type are appropriate for net heads ranging from several meters up to more than 30 m. In addition, civil works using this type of turbine are considerably simplified.

In the following sections we will highlight those mechanical designs and hydrodynamic characteristics of the Saxo-type turbines that seem to be, at the moment, the most interesting and promising.

2. CONSTRUCTION OF THE TURBINE

A particular subject of our interest is a turbine with the parameters as follows: runner diameter = 1900 mm; number of runner blades = 5; number of guide vanes = 12; speed of rotation = 300 rpm; nominal net head = 21.2 m; and nominal operating discharge between $Q = 9 \text{ and } 27 \text{ m}^3/\text{s}$. Figure 2 shows schematically a typical design of a Saxo type turbine unit.

A high pressure reference section, needed for turbine performance consideration, is set in front of the inlet elbow, which is, by convention, an integral part of the turbine. Such types of elbows are rather unusual parts of standard turbine configurations. Compact elbows with guide vanes have been quite well investigated (Idelchik, 1986). The main parameter of interest is the loss coefficient. Providing the guidelines for the design of the casing and vanes are followed, and the cross-section reduction due to shaft presence is taken into account, the energy loss coefficient ζ stays between 0.2 and 0.21. According to the information from the above mentioned reference, it would be possible to slightly improve on a 90° elbow for obtaining a loss coefficient that approaches 0.195. This aim would be achieved by increasing the number of profiled vanes.

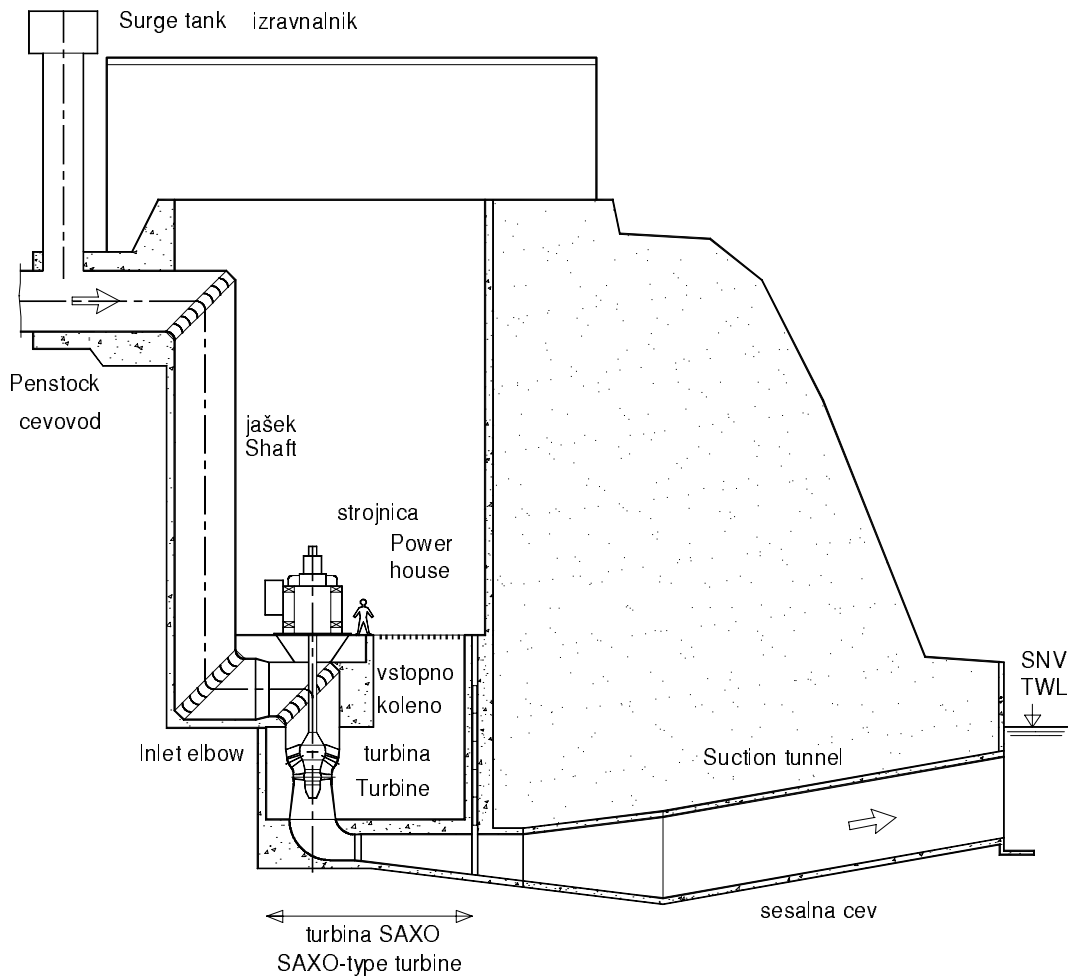

Slika 1. Hidroelektrarna z značilnim pretočnim traktom turbine vrste Saxo.
 Figure 1. Hydroelectric power plant with a typical Saxo-type turbine water passage system.

Ena večjih pridobitev naše konstrukcije je z vodo mazani in hlajeni vodilni ležaj ob gonilniku turbine. Material ležajne obloge je lahko liti polimer, PTFE (komercialno ime teflon) z dodatki ali sintrana kovina na bazi bronca. Z izbiro takega ležaja se rešimo skrbi z oljem ali mastjo, izvedba tesnenja vrteče se gredi proti okrovu turbine je preprosta, proti vodni strani pa posebna tesnilka ni potrebna. Sistem mazalne in hkrati tesnilne vode mora biti preiščen (filtriranje, vzdrževanje tlaka oziroma pretoka), kajti preprečiti je treba, da bi umazana voda iz turbinskega trakta prišla v ležaj tudi, ko turbina stoji. Ta problem je uspešno rešen z zaprtim sistemom mazalno-tesnilne vode, ki je tudi že uspešno uveljavljen.

Naslednja prednost turbine Saxo je toga konstrukcija ter vertikalna os vrtenja. Pri izvedbi turbine z nizkimi vrtiljaji je mogoče

One of the very significant advantages of our design is the application of a standard water lubricated and cooled turbine guide bearing. The material of the bearing shells might be moulded polymer, PTFE (commercially named Teflon) with additives, or sintered metal based on bronze. The choice of such a bearing avoids the use of oil or grease; the sealing of the shaft at the turbine case side is quite simple, while, at the waterside, sealing is not necessary. The system of lubricating-sealing water should be carefully considered (filtering, maintaining pressure, i.e., discharge, etc.) because the inflow of the unclean water from the turbine passage should also be prevented when the turbine is not operating. This problem has been successfully solved by using a closed system of lubricating-sealing water that has already been successfully applied.

The next advantage of the Saxo turbine is its rigid structure and the alignment of the vertical turbine shaft. In turbines with low a

mnogo-polni in težki generator, ki je hkrati tudi vztrajnik, pritrjeni neposredno na okrov oziroma vstopno koleno turbine. Še boljša rešitev je ta, da se za generator predvidi posebno sidranje na betonski blok ob in okoli kolena turbine. Spodnji ležaj generatorja je obenem drugi vodilni ležaj turbine, nosilni (aksialni) ležaj generatorja pa prevzame tudi obremenitve turbine.

speed of rotation, it is possible to attach a multi-pole generator with a high flywheel effect. The generator might be settled at the top of the inlet elbow casing. Sometimes it is better to fix the generator anchoring to the concrete block built around the turbine. The bottom bearing of the generator is, at the same time, the guide bearing of the turbine, while the thrust (axial) bearing of the generator takes the loading of the turbine, as well.

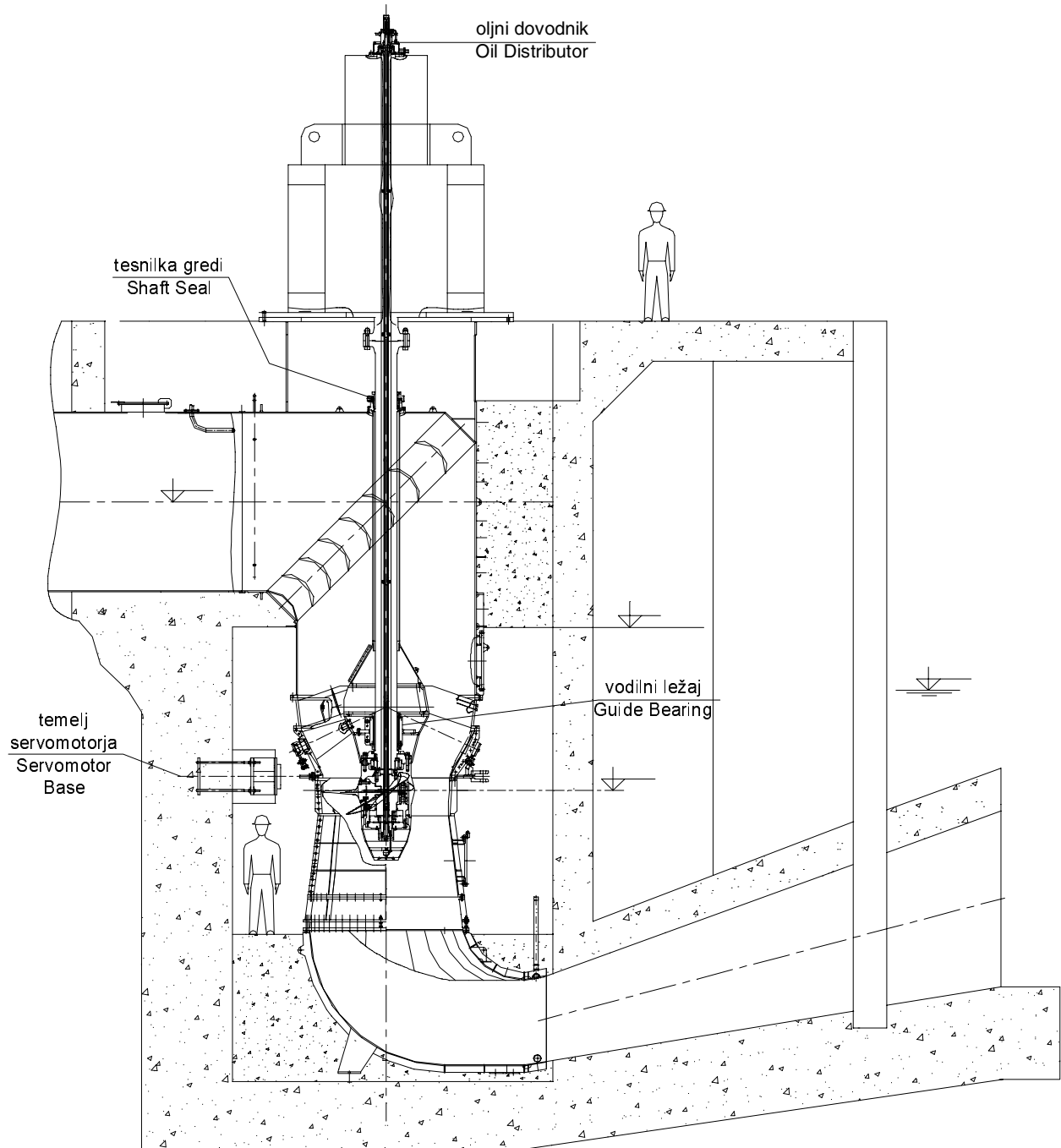

Slika 2. Primer konstrukcije turbine Saxo.
Figure 2. Construction example of a Saxo-type turbine.

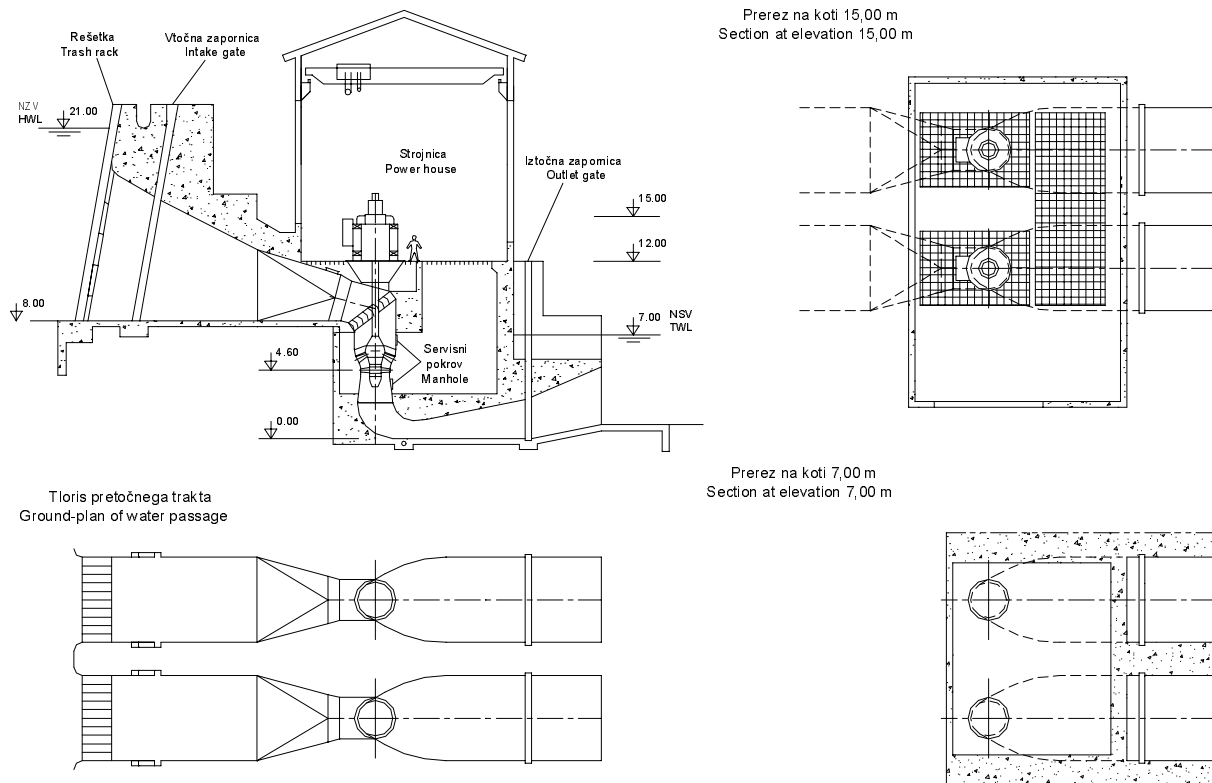

Slika 3. Pretočna elektrarna s turbinama Saxo – strojnica je v sklopu pregrade ali tik ob pregradi.
 Figure 3. Run-of-river power plant with Saxo-type turbines – power house is integral part of the
 barrage or it is close to the barrage.

Oljni dovodnik je element v hidravličnem sistemu za premikanje lopat gonilnika. V dovodniku olje pod visokim tlakom prehaja iz mirujočih cevi na vrteče se cevi, ki so nameščene v votli gredi generatorja in turbine. Dovodnik je mogoče namestiti samo na vrh generatorja ob prazen štrcelj gredi. Tu je tudi najbolj primerno mesto z vidika kontrole in vzdrževanja.

Skopo opisane konstrukcijske značilnosti turbine Saxo so hkrati tudi znane prednosti kaplanovih turbin, ki odtehtajo v tekmi med cevnimi in kaplanovimi turbinami. V zadnjem obdobju se načrtovalci hidroelektrarn (spodnja Sava) raje odločajo za kaplanove, ravno zaradi določenih prednosti pri pogonu in vzdrževanju, kot tudi možnosti namestitve generatorjev z velikimi vrtečimi se masami, čeprav bi bile s stališča hidroenergetike in

The oil distributor is the device of the hydraulic system that is necessary for setting the angle of the runner blades. In the oil distributor, the oil under high pressure flows from the static tubes to the rotating tubes which are installed inside the hollow generator and the turbine shaft. It is only possible to install the oil distributor at the top of generator at the free end of the shaft. This is also the best choice from the point of view of control and maintenance.

In addition to the above mentioned and shortly described characteristics of Saxo-type turbines, there are well known advantages of Kaplan turbines, which are crucial in competition between tubular and Kaplan turbines. During recent years, investors in hydropower plants have been used to choosing Kaplan turbines, primarily because of their advantages during operation and maintenance, and the possibilities of easily installing generators with large rotating masses, in spite of the fact that tubular turbines would have

gradbenih del primernejše cevne turbine. Saxo turbine pa ponujajo zanesljivost in trpežnost kaplanovih turbin in odlične hidravlične karakteristike cevnih turbin, kot bomo pokazali s študijo v naslednjem poglavju. Kot primer vgradnje turbine Saxo v rečno pregrado hidroelektrarne kaže slika 3. Okoli okrova turbine, ki je v največji meri zalito v beton, se da razmestiti vse posluževalne platoje in pomožne sisteme turbine.

3. HIDRODINAMIČNE ZNAČILNOSTI

Teoretične in računske raziskave turbine Saxo so bile osredotočene na vodilnik, prostor med vodilnikom in gonilnikom ter tok skozi gonilnik (Höfler et al., 1997). Najprej je uporabljena metoda računa toka po metodi krivih tokovnic (SCM), kot da bi na novo zasnovali gonilnik turbine. Ob tem je upoštevan realni vodilnik in oblika vodilnih lopat. Druga metoda analize je bila s pomočjo CFD računalniškega paketa za realni fluid (TASCflow). Modeliran je pretočni trakt od vodilnika do konca sesalnega konusa. Analizirana so različna odprtja vodilnika za en nastavni kot gonilnikovih lopat. Rezultate, dobljene po CFD metodi, upoštevamo kot referenčne.

Posebno pozornost smo posvetili vodilniku turbine in njegovemu vplivu na strukturo toka tik pred gonilnikovimi lopatami. Za uspešno napoved tokovnih razmer v pretočnem traktu turbine moramo poznati:

- povezavo med odprtjem vodilnika in vrtincem, ki ga vodilne lopate ustvarjajo
- realni pretočni presek vodilnika oziroma "blockage factor".

Na podlagi znanih prvih dveh podatkov lahko napovemo izgube energije zaradi mešanja toka za vodilnikom.

been more appropriate from the point of view of civil works and hydroenergetics. In the next section we will show that Saxo turbines offer both the reliability and endurance of Kaplan turbines and the excellent hydraulic characteristics of tubular turbines. An example of a Saxo turbine installed in the barrage of a run-of-river power plant is shown in Fig. 3. It is obvious that around the turbine casing, of which the main part is embedded in concrete, it is possible to distribute all the necessary users platforms and auxiliary equipment.

3. HYDRODYNAMIC FEATURES

In previous work (Höfler et al., 1997), the theoretical and numerical investigations were focused on the regions of the guide vanes and the runner blades, as well as on the region between them. At first the streamline curvature throughflow method (CSM) was applied, as it is used for designing a new runner blade row, considering the real apparatus and the real shape of the guide vanes. The second step was the flow field analysis, performed by using CFD for viscous turbulent flow (TASCflow). Flow passage was modelled between the conical distributor inlet and the conical diffuser outlet. Analysis was performed for different guide vane openings, keeping the angle of runner blades in a fixed position. These results are assumed to be reference for present investigations.

Special attention was paid to the conical guide apparatus and its effects on the flow pattern immediately in front of the runner blades. For a successful prediction of the flow field through the turbine passage, the following parameters have to be identified:

- Correlation of the guide apparatus opening and the swirl created by the guide vanes
- Actual flow cross-sections of the guide apparatus and the "blockage factor", respectively

Based on these data it is possible to predict the energy losses due to flow-mixing downstream of the guide vanes.

Vodilne lopate polaksialnega ali koničnega vodilnika so zavite samo vzdolž profila, vsi parametri profila (dolžina in debelina profila ter ukrivljenost skeletnice) so premosorazmerni oddaljenosti preseka profila $D_x/2$ od središča vodilnika. Na sliki 4 so prikazane značilne veličine koničnega in radialnega vodilnika. Skladno s konvencijo zapišemo brezdimenzijsko odprtje vodilnika a_0 , ki ima z_g lopatic:

$$a_0 = A_g \cdot z_g / D_x \quad (1)$$

kjer je D_x premer, na katerem se opravi meritev fizičnega odprtja A_g . Tako definirano odprtje vodilnika enoznačno določa naklon - nastavitev lopat vodilnika in obratno. V prehodu med dvema vodilnima lopatama pridobi vodni tok določeno hitrost in smer in s tem tudi obodno komponento hitrosti c_u . Tako je na obravnavani tokovni plasti cirkulacija nasproti vrtilni osi turbine podana z izrazom:

$$\Gamma = 2 \cdot \pi \cdot r \cdot c_u \quad (2)$$

where D_x represents the characteristic diameter of the guide apparatus sphere where the opening A_g has to be measured. In this way, the defined guide vanes opening determine uniquely the angle of the guide vanes. In the guide vanes passage, the water flow acquires a predetermined velocity, and, consequently, also a certain circular velocity component c_u . At an arbitrary streamlayer, the circulation Γ around the shaft rotation axes is given by:

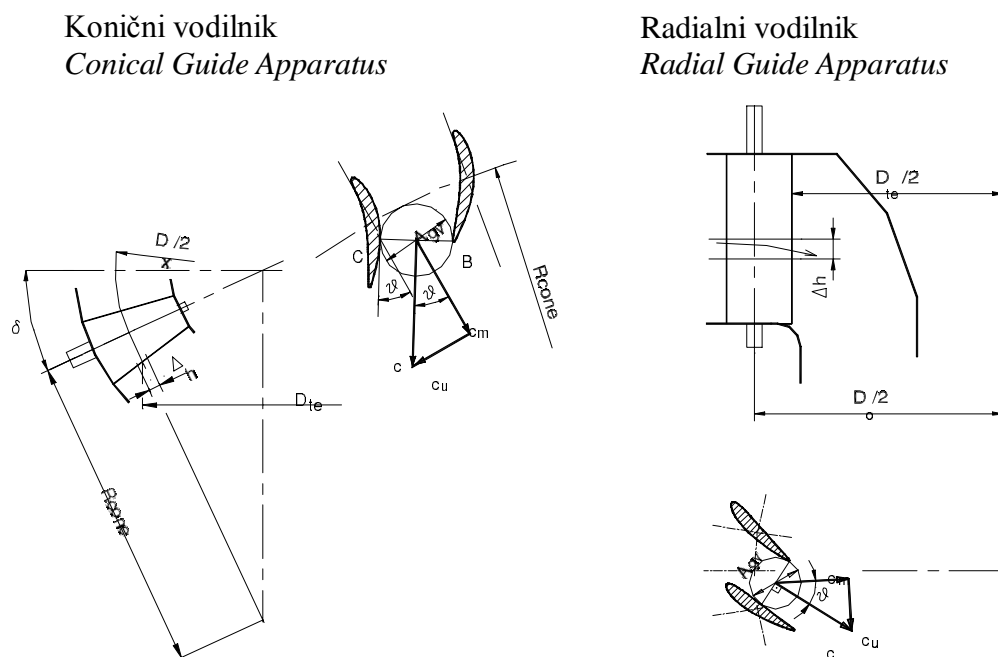

Slika 4. Opis geometrije vodilnika in lopatic.
 Figure 4. Guide apparatus and guide vane geometry description.

Za konični vodilnik, ki se uporablja v cevni in Saxo turbini, smo ugotovili zvezo med odprtjem vodilnika a_0 in smerjo ali kotom vrtnica $\vartheta = \vartheta(a_0)$. Potek te funkcije je prikazan na sliki 5; kot je neodvisen od lege opazovanega preseka (premer D_x) vzdolž višine lopate in velja za vse konične vodilnike, ki so podobni obravnavanemu vodilniku.

Vodilnik je generator vrtnica, vendar predstavlja tudi določeno oviro vodnemu toku, zlasti ko ni polno odprt. Oviro definiramo s faktorjem ($B_{gv} < 1$) kot blokiranje pretočnega preseka. Tudi ta faktor je močno odvisen od odprtja vodilnika a_0 :

$$B_{gv} = \frac{a_0 \cdot B_A \cdot D_x}{\pi \cdot \cos \vartheta \cdot D_2} \quad (3)$$

Z naslednjim faktorjem ($B_A < 1$) zajamemo blokiranje prehoda A_g zaradi realnega profila hitrosti c . Očitno je faktor blokiranja B_{gv} odvisen samo od odprtja vodilnika a_0 in vpeljanega empiričnega faktorja B_A , katerega razpon je lahko za tok brez odlepitve v mejah $0.92 < B_A < 0.98$. Upoštevamo zvezo med absolutno hitrostjo c , meridiansko komponento c_m ter kotom vrtnica ϑ v grlu vodilnika

$$c_m = c \cdot \cos \vartheta \quad (4)$$

Z naslednjo preglednico primerjamo značilne hidrodinamične veličine vzdolž višine h vodilnika:

	konični (polaksialni) vodilnik cevena turbina	radialni vodilnik kaplanova turbina
kot vrtnica	$\vartheta(h) = \text{konst}$	$\vartheta(h) = \text{konst}$
meridianska hitrost		
vstop	$c_m(h) = \text{konst}$	$c_m(h) = \text{konst}$
izstop	$c_m(h) \neq \text{konst}$	$c_m(h) = \text{konst}$
obodna hitrost	$c_u(h) \neq \text{konst}$	$c_u(h) = \text{konst}$
vrtilna količina	$(r \cdot c_u)(h) \neq \text{konst}$	$(r \cdot c_u)(h) = \text{konst}$

For the conical guide apparatus which is used in tubular and Saxo turbines, we found the empirical relation $\vartheta = \vartheta(a_0)$, which enables us to obtain the swirl angle ϑ as the function of the guide vanes opening a_0 . This function is given in Figure 5; the angle is independent of the position of the cross-section (diameter D_x) along the height of the vane, and is valid for the arbitrary conical apparatus, which is designed in a similar manner.

Guide vanes represent a swirl generator; however, they partially obstruct the flow, especially when the opening is not full. This constraint is defined via factor ($B_{gv} < 1$), that describes the blocking of the flow cross-section. The factor B_{gv} strongly depends on the guide vanes opening a_0 :

Factor B_A , that is less than one, describes the blocking of the passage A_g , due to the actual distribution of the velocity c . It is obvious that the blocking factor B_{gv} depends only on the guide vane openings a_0 , and the empirically implemented factor B_A , which, for the flows without separation, ranges between 0.92 and 0.98. We take into account the relationship between the absolute velocity c , its meridional component c_m and the angle ϑ in the throat of the guide passage

Characteristic hydrodynamic quantities, distributed along the vane height h , are compared in the following table

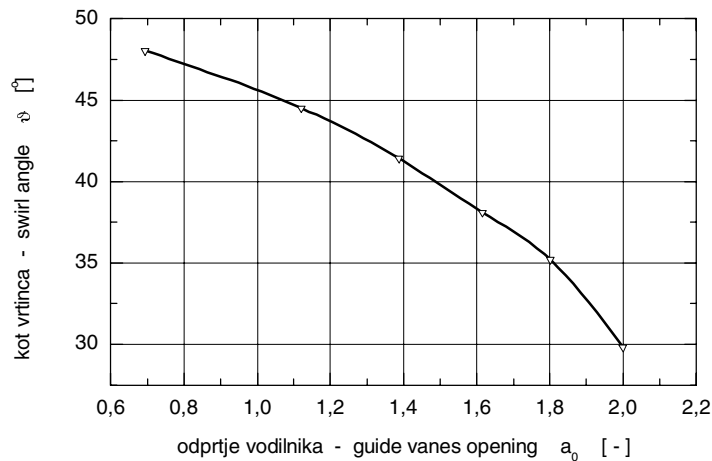

Slika 5. Grafično dobljena odvisnost kota vrtnica od relativne odprtine vodilnika.
 Figure 5. Graphically estimated swirl angle versus the guide vane opening.

4. RAZMERE PRED GONILNIKOM TURBINE

Eulerjeva turbinska enačba pove, da se koristno delo na obodu gonilnika opravi samo ob spremembi vrtilne količine - zmnožek ($r \cdot c_u$) - ali cirkulacije na poti med vstopom in izstopom iz lopatičnega kanala gonilnika, kot je prikazano na sliki 6. Na tej sliki pomenijo oznake c , w in u absolutno, relativno in sistemsko hitrost na cilindričnem prerezu. Na lopate gonilnika se prenese največ energije, če odtekajoči fluid nima več vrtnica - $(r \cdot c_u)_2 = 0$. Ob tej predpostavki dobimo neposredno zvezo med vstopnim vrtnicem in specifičnim delom $E = g \cdot H$, ki naj se opravi na delni turbini (Barlit, 1977):

$$(r \cdot c_u)_1 = \eta_t \cdot \frac{g \cdot H_n}{\omega} \quad (5)$$

kjer je: g - zemeljski pospešek, H_n - neto padec turbine, η_t - izkoristek turbine in ω - kotna hitrost gonilnika.

4. CONDITIONS AT THE FRONT OF THE RUNNER

The Euler turbine equation states that the effective work on the circumference of a runner is achieved only due the change of the moment of momentum ($r \cdot c_u$), i.e., due to the circulation drop between the inlet and the outlet of the runner blade channel, as shown in Figure 6. In this figure showing a cylindrical blade cross-section, c and w denote absolute and relative fluid velocity and u is the system velocity or so-called "blade speed". The energy transfer is most efficient when the outflowing fluid is without any circulation - $(r \cdot c_u)_2 = 0$. Under this assumption, we obtain the direct relationship between the inflow circulation and the specific work $E = g \cdot H$, done in the partial turbine (Barlit, 1977):

in which: g is acceleration due to gravity, H_n is turbine net head, η_t is turbine efficiency and ω is runner angular velocity.

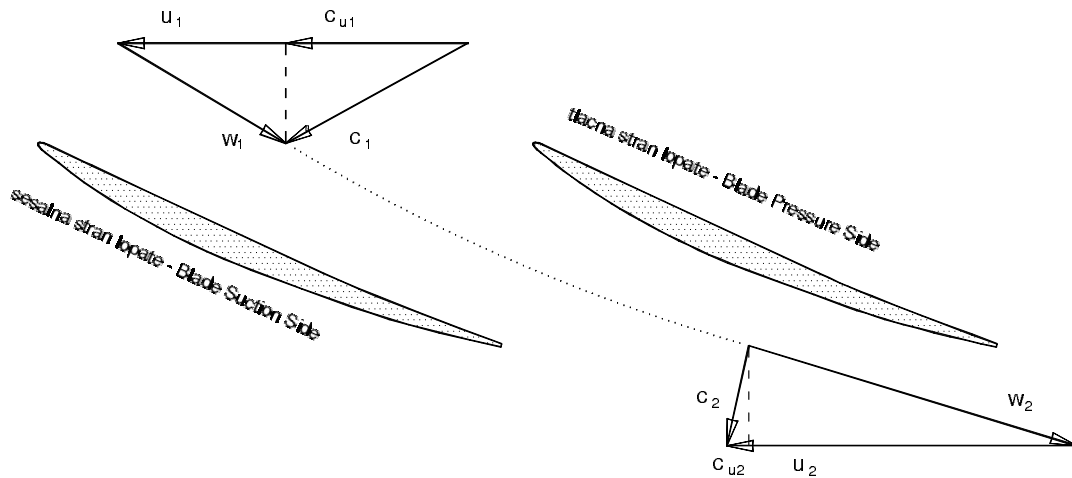

Slika 6. Geometrija lopatičnega venca gonilnika na cilindričnem prerezu in pripadajoča trikotnika hitrosti.

Figure 6. Runner blade row geometry on a cylindrical section and related velocity triangles.

Od porazdelitve vrtnica vzdolž vstopnega roba lopate gonilnika je močno odvisno, koliko energije se lahko predela na posamezni tokovnici oziroma delni turbini. In če se lotimo optimiranja lopat gonilnika za določeno energijsko višino turbine ($g \cdot H_n$), mora temu nujno slediti različna oblika lopate, glede na to ali je vodilnik radialni ali pa konični.

Na sliki 7 prikazujemo računsko dobljene porazdelitve hitrosti tik pred vstopnim robom gonilnika turbine Saxo. Nato je na sliki 8 predstavljen študijski primer optimirane oblike lopate za obravnavano turbino. Za projektno delovno točko (design duty point) je prikazana porazdelitev tlačnega koeficienta C_p na obeh ploskvah lopate. Tlačni koeficient C_p je namreč odličen pokazatelj obtokanja površine lopate (Lewis, 1996), nanaša se na iztočne razmere, definiran pa je takole:

$$C_{p2} = \frac{p - p_2}{\rho \cdot w_2^2 / 2} \quad (6)$$

kjer je: p – lokalni tlak, p_2 – referenčni tlak na sredini izstopa medlopatičnega kanala, ρ – gostota fluida, in w_2 – relativna hitrost fluida v referenčni točki.

Kakšne so razmere na dejanski lopati gonilnika turbine, ki je bila izdelana in obratuje, kaže slika 9. S pomočjo programa za CFD je izračunana porazdelitev tlačnega koeficienta C_p za enako delovno točko kot za

The rate of the energy transfer at a particular streamtube, i.e., partial turbine, is strongly dependent on the distribution of the circulation along the leading edges of the runner blades. Henceforth, optimising the runner blades for any particular net head of the turbine ($g \cdot H_n$) must be followed by an appropriate choice of different blade shapes, depending on whether the guide apparatus is radial or conical.

In Figure 7, we show the calculated velocity distributions in front of the runner blades of the Saxo turbine. In Figure 8, sample results are shown of our blade shape optimising study for the corresponding turbine. The distribution of the pressure coefficient C_p , at both sides of the blade is shown as obtained at the design duty point. This coefficient, which is an excellent measure of the flow around the blade (Lewis, 1996), and which relates to the outflow conditions, is defined as

in which p is local pressure, p_2 is reference pressure in the middle of the outflow section of the blade channel, ρ is fluid density and w_2 is the fluid relative velocity in the reference point.

Actual conditions taking a role in the performance of a turbine which has been built and is currently operating, are shown in Figure 9. The distribution of the pressure coefficient C_p has been calculated by applying the CFD

študijski primer na sliki 8. Metode računalniške dinamike fluida (CFD) nam omogočajo podroben vpogled v tokovne razmere. Tako vidimo, da pri resnični lopati (Slika 9) na zunanem predelu vstopnega roba lopate prihaja do močnih sprememb tlaka, kar z vidika izgub energije in razvoja kavitacije prav gotovo ni dobro.

5. SKLEP

Kratka in groba analiza konstrukcijskih in hidravličnih značilnosti turbine Saxo je pokazala nedvomne prednosti te vrste turbine. Obravnavana vrsta turbine ima pogonske prednosti in preprosto vzdrževanje kaplanovih turbin ter hidroenergetske in konstrukcijske prednosti cevnih turbin. Konični ali polaksialni vodilnik ustvarja rahlo vsiljeni vrtinec z ustrežnejšo porazdelitvijo obeh glavnih komponent hitrosti pred lopatami gonilnika. Rezultati računske analize nakazujejo možnosti za nadaljnje optimiranje vseh elementov pretočnega trakta turbine. Med drugim bi bile lopate gonilnika lahko manj zavite, z manjšim gradientom tlaka po površini lopate in tako poznejšim razvojem kavitacije. Vse te obetavne napovedi bi bilo treba potrditi s preskusi na modelu turbine.

code at the same operating point as shown in the example in Figure 9. This method enables a detailed inspection of the flow conditions. For example, one can see that in the case of an actual blade, at the peripheral side of its leading edge, there are considerable pressure variations, which are not desirable from either point of view, that of energy losses or cavitation.

5. CONCLUSION

A short and still rather rough analysis of the construction and hydraulic features of the Saxo-type turbine have demonstrated their obvious advantages. This turbine, at the same time, has both the advantages of the Kaplan and the tubular turbines, such as simple maintenance, simple construction characteristics and good operation performances. A conical, i.e., a semi-axial guide apparatus generates a slightly forced swirl with more appropriate distribution of the main components of the velocity in front of the runner blading. The results of numerical investigations indicate that there are still open possibilities for the further optimising of all parts of the flow passage. For example, the runner blades may be more gently twisted with a decreased pressure gradient along the blade surface, and, consequently, be less sensitive to cavitation. All these predictions should be confirmed by experiment.

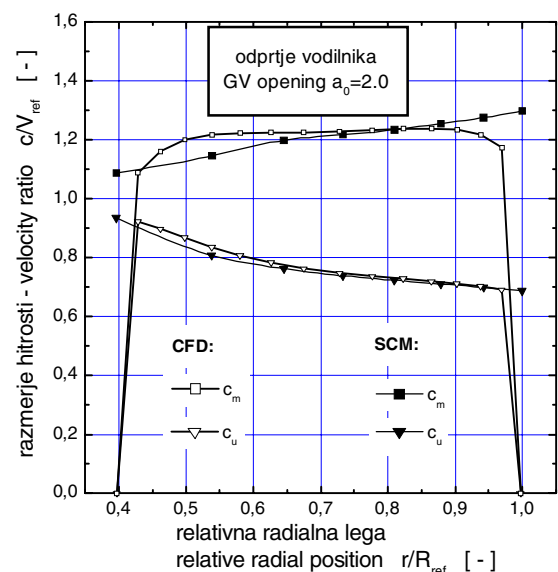
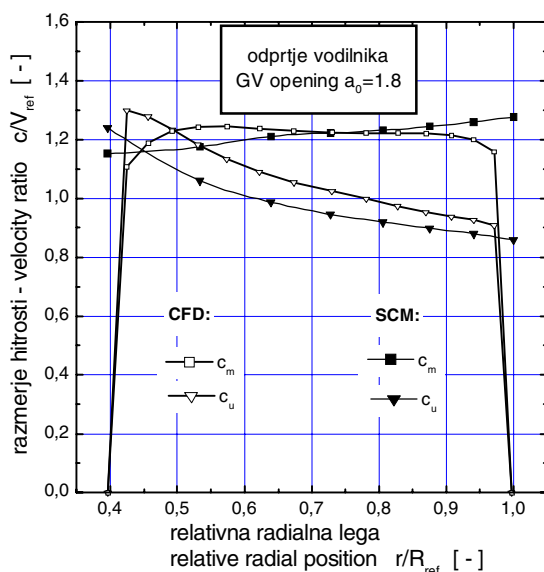

Slika 7. Izračunane porazdelitve hitrosti pred vstopnim robom lopate gonilnika.
 Figure 7. Computed velocity distribution at the front of a runner blade row.

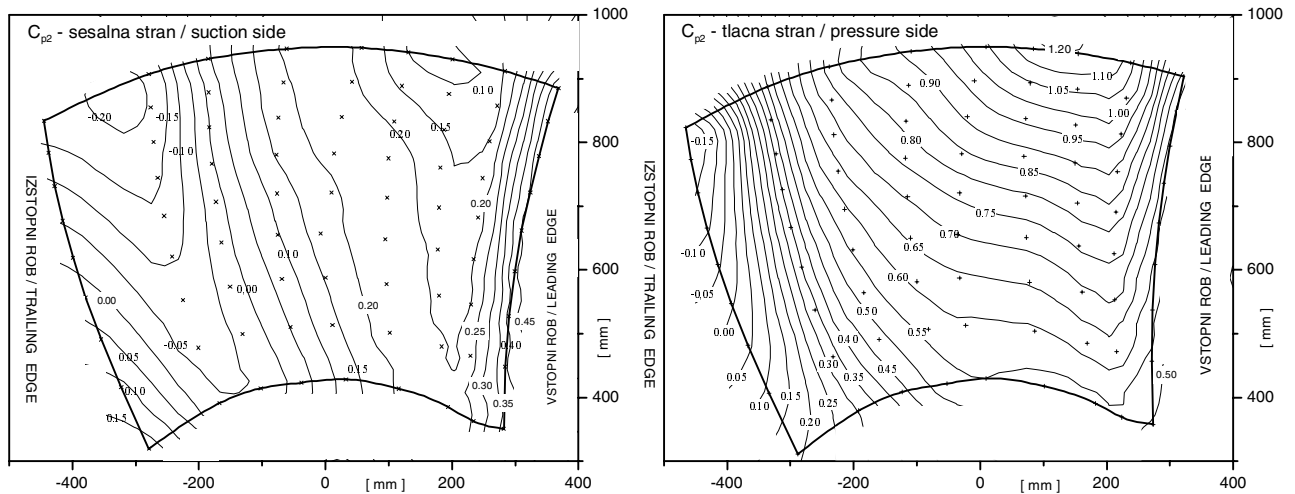

Slika 8. Študijski primer optimiranja gonilne lopate turbine Saxo – z računsko metodo krivih tokovnic (SCM) napovedana porazdelitev tlačnega koeficienta na površini lopate
 Figure 8. Distribution of surface pressure coefficient predicted by SCM for an optimising study runner blade of a Saxo turbine.

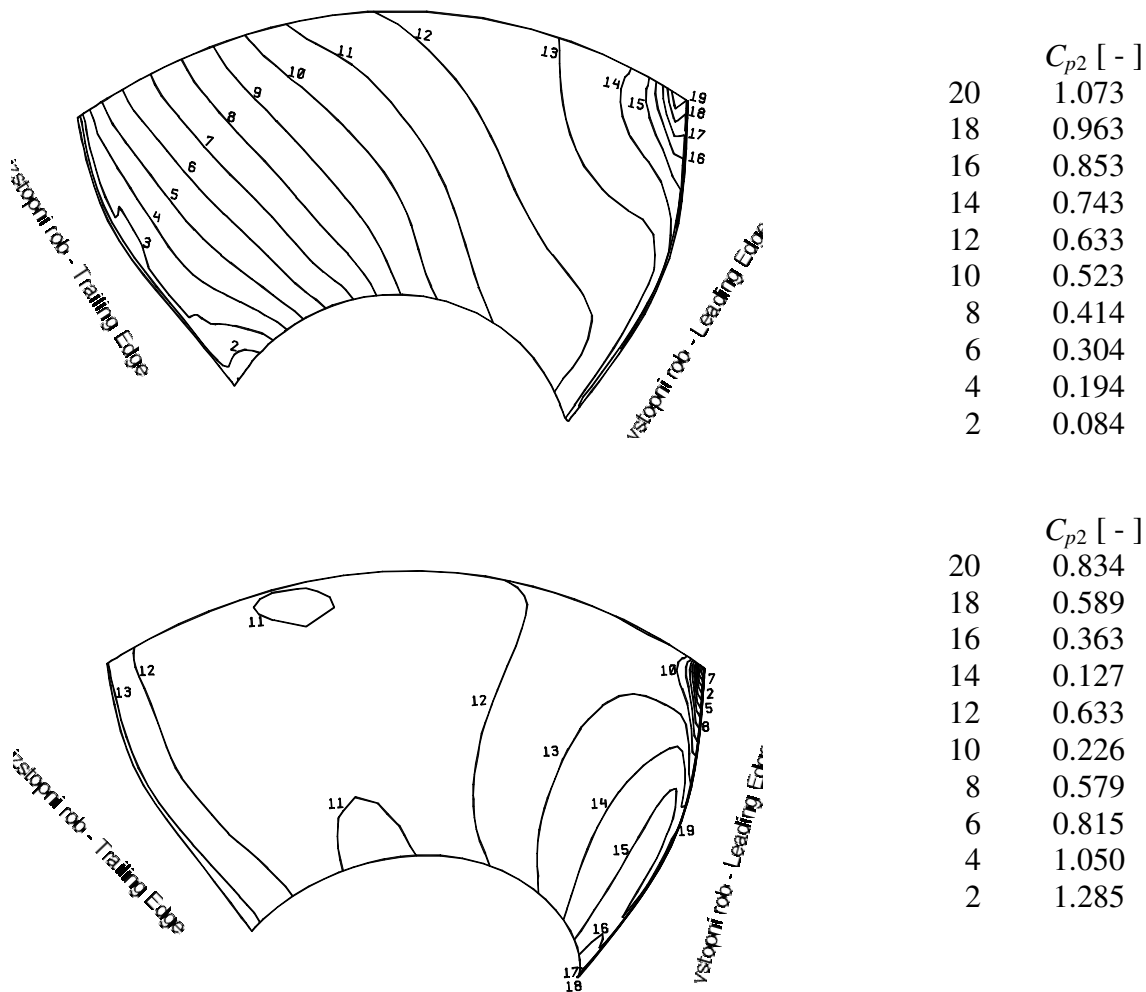

Slika 9. Lopata gonilnika izvedene turbine Saxo – z računsko metodo CFD napovedana porazdelitev tlačnega koeficienta na površini lopate
 Figure 9. Distribution of surface pressure coefficient predicted by CFD for a realised runner blade of a Saxo turbine.

VIRI - REFERENCES

- Idelchik, I.E. (1986). *Handbook of Hydraulic Resistance*, 2nd Ed., Hemisphere Publishing Corporation.
- Hoefler, E., Jelić, N., Kolšek, T. (1997). Numerical flow analysis in SAXO turbine by using different methods. Proceedings of the International Conference on Hydropower into the Next Century, Portorož, September 1997, 173 - 184.
- Barlit, V.V. (1977). *Gidravličeskie turbiny* (Hydraulic turbines), Izdatel'skoe ob'edinenie "Viš'a škola", Kiev (in Russian).
- Lewis, R.I. (1996). *Turbomachinery Performance Analysis*. ARNOLD, London.

Naslov avtorja - Author's Address

Edvard HÖFLER
Litostroj E.I. d.o.o.
Litostrojska 40, SI - 1000 Ljubljana
Email: edvard.hoefler@litostroj-ei.si